

Garrard DD75

Garrard

Model DD75 Direct Drive Turntable

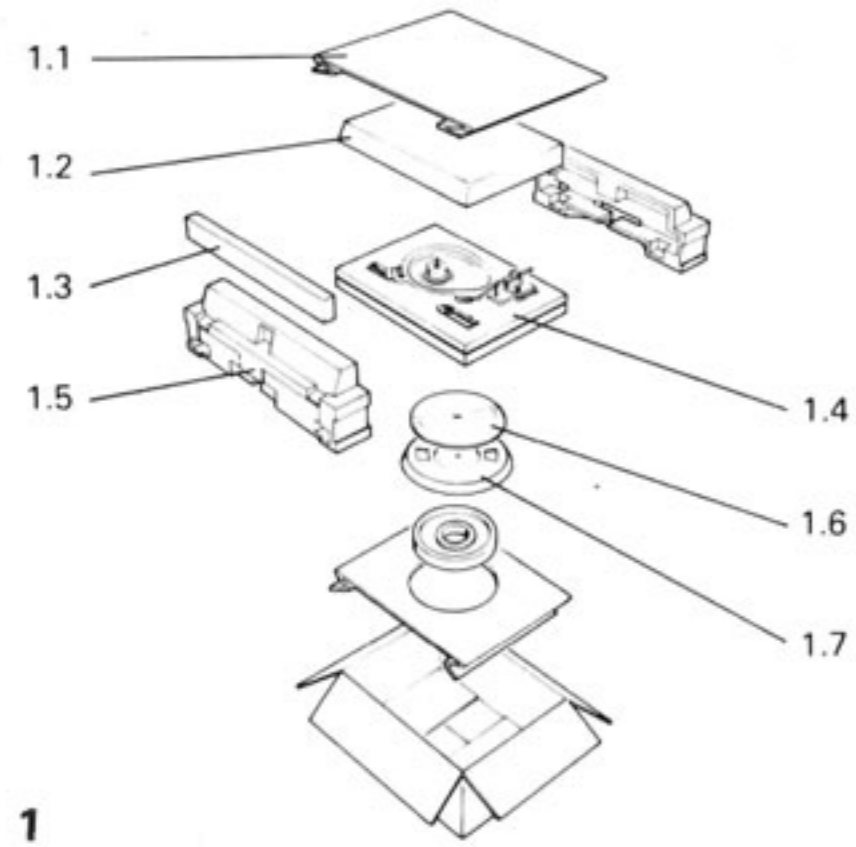

1

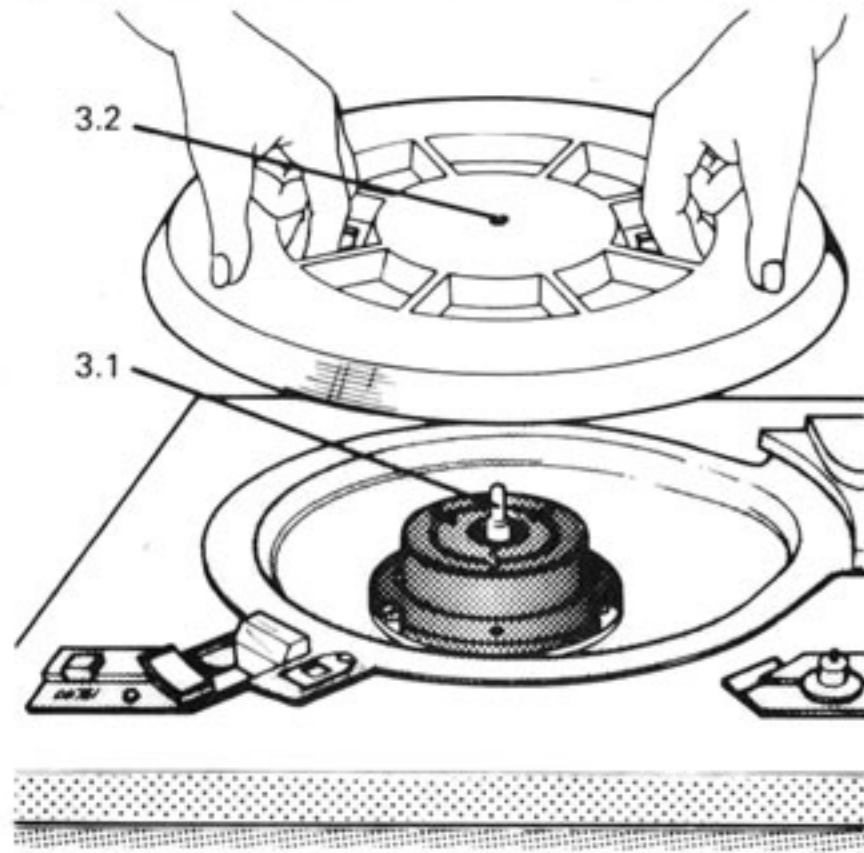

3

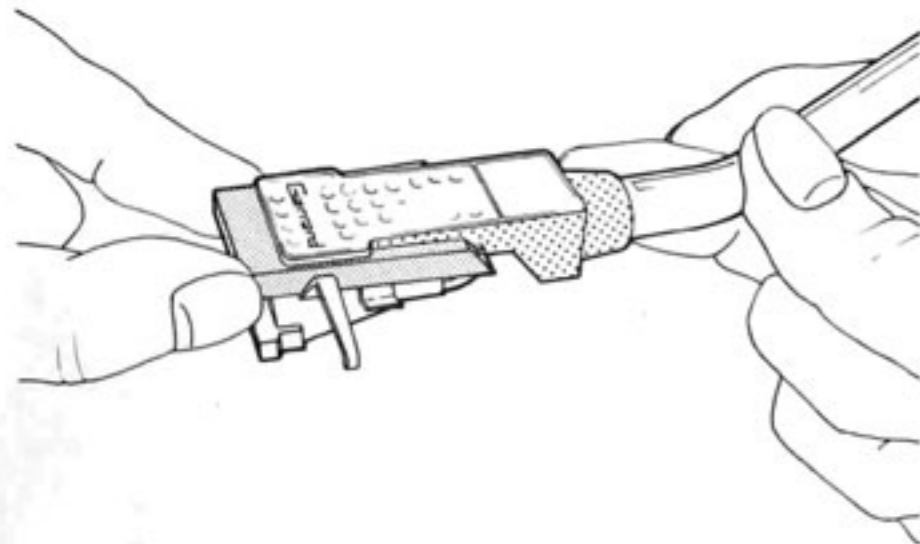

5

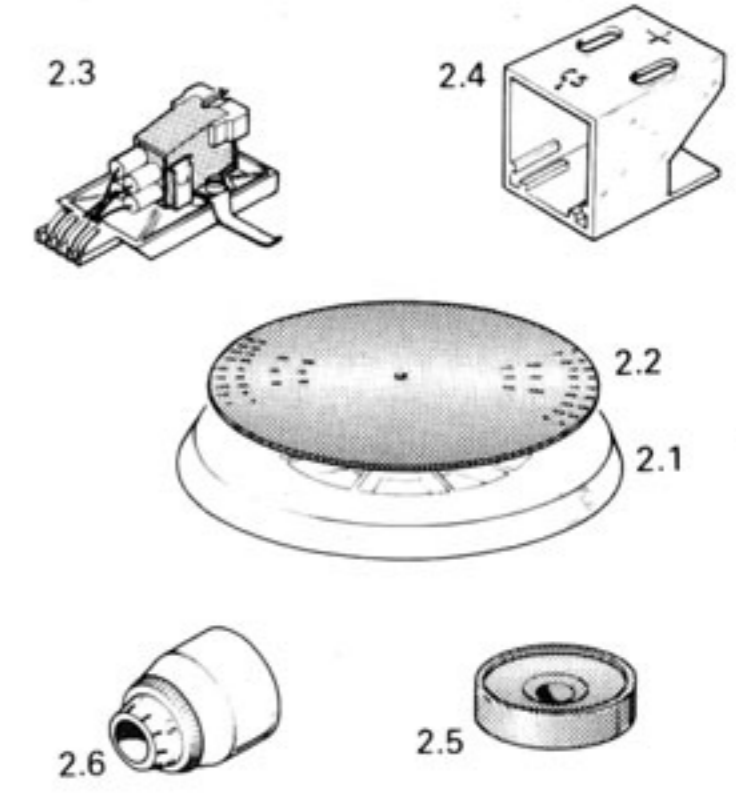

2

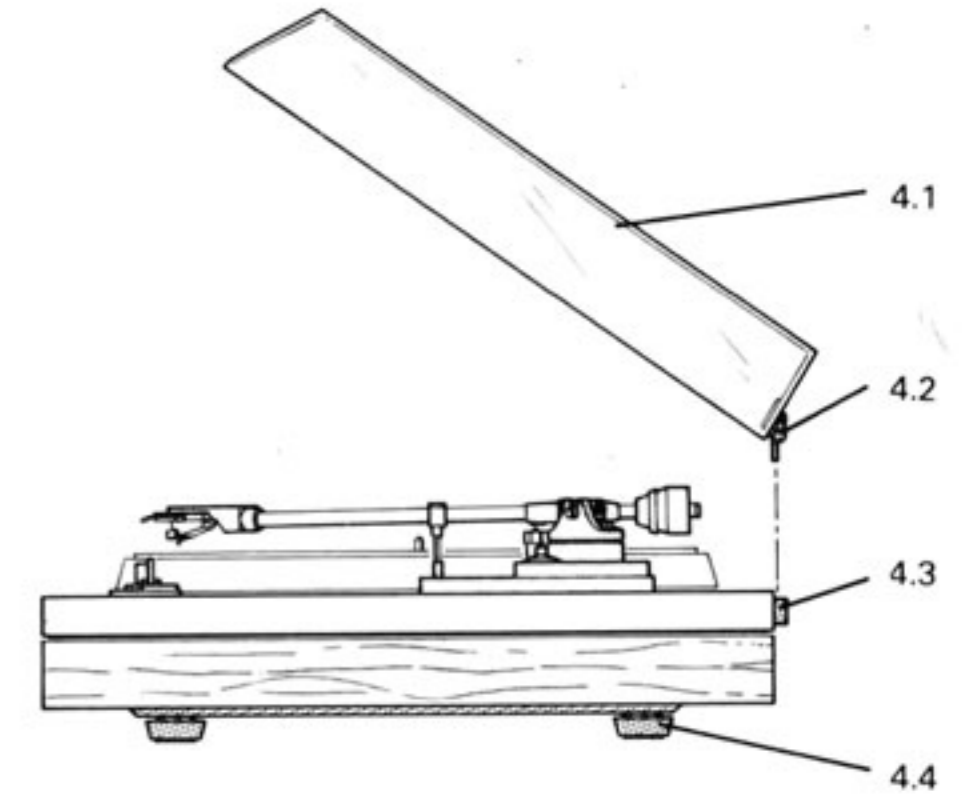

4

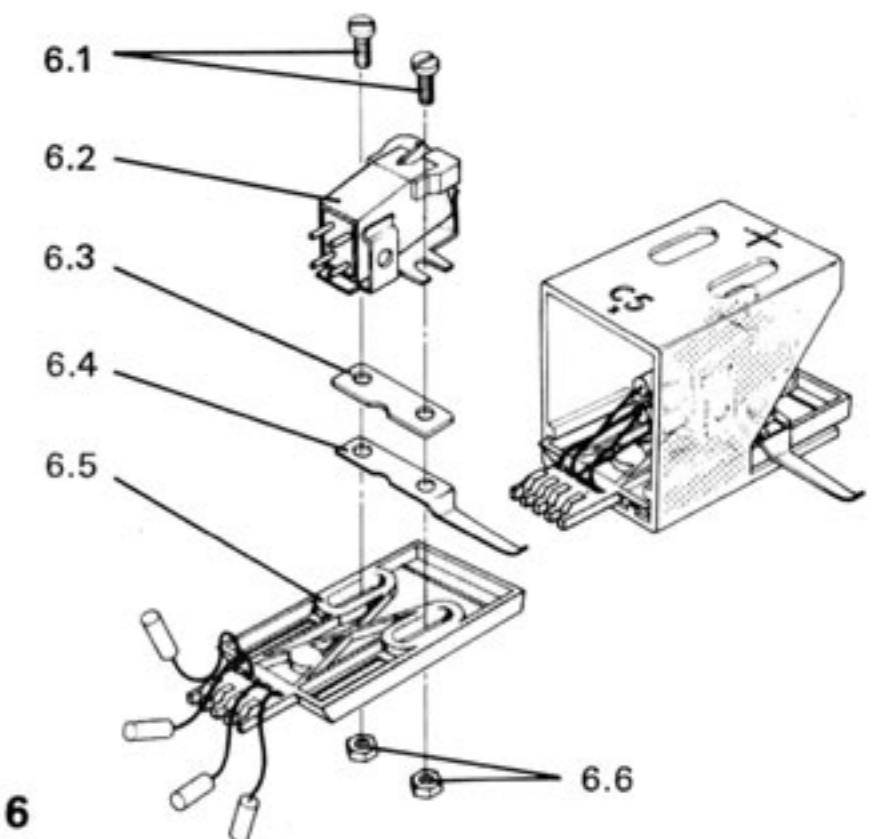

6

The Garrard Tradition

At Garrard, simple precision and mechanical integrity have always held a high priority over glamour features and hi-fi pizzazz.

Like a chemist's analytical balance or a gyroscope, a high fidelity turntable has certain basic mechanical functions that require the utmost precision. The correct rotation of the record and the correct seating of the stylus in the record groove are fundamental. Only then come all the other conveniences that make record playing pleasurable.

This emphasis on fundamentals is the primary reason that Garrard is one of the world's classic names in high fidelity.

The DD75 direct drive turntable is one of Garrard's proudest achievements.

Special note: Model DD75 offers a very high standard of performance. To take advantage of this, use only a pickup cartridge of equally high specification. If you require a cartridge and are in doubt about its suitability, consult a reputable hi-fi dealer.

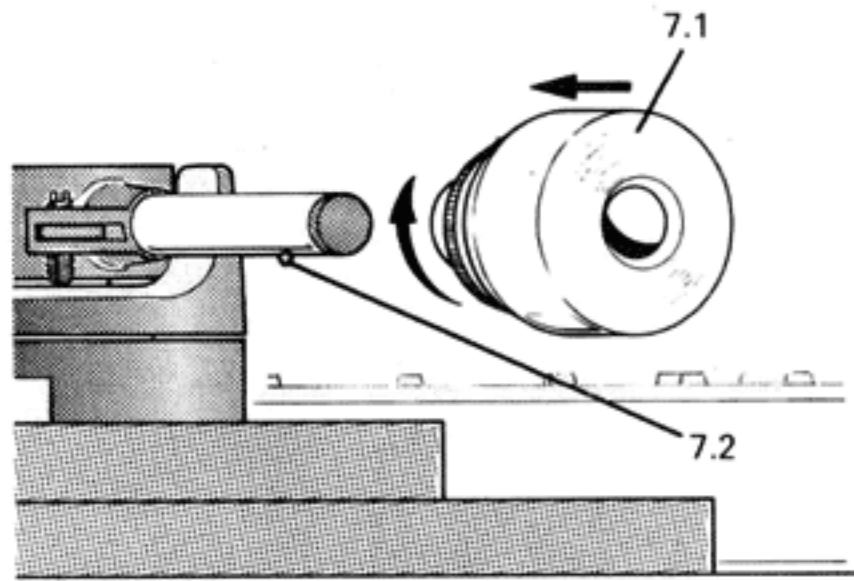

7

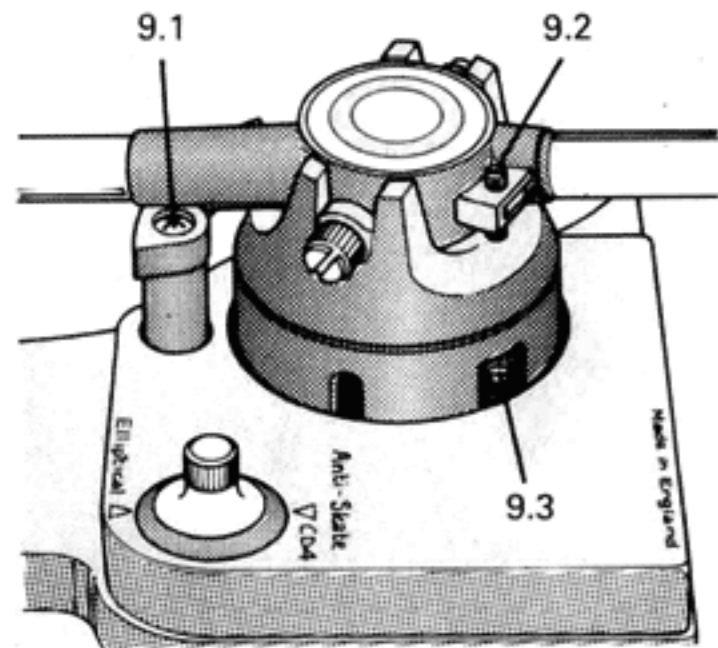

9

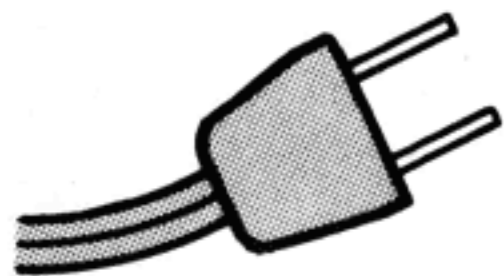

11

General description

The DD75 is a new direct drive turntable designed to play your records with consummate care.

The motor is multi-pole, brushless DC, and Servo controlled. It revolves at precisely the same speed as the record without need of belts, idlers or other reduction mechanisms. The speed is regulated by a system of sophisticated electronics that provide precise, constant rotation. The electronics also provide the capability of varying the speed to correct off-pitch recordings. This is done via a variable speed control; accuracy can be monitored by reference to a large, well-illuminated stroboscope.

The heavy, 4lb platter is of die-cast aluminum and is dynamically balanced. Both its weight and its construction add to the ability of the DD75 to rotate a record with absolute accuracy and freedom from vibration.

The S-shaped tubular, extruded aluminum tonearm is designed for minimum tracking error. It has very low mass (16gm) and rides on jewel cross bearings. It is counterbalanced on low friction pivots.

Every feature of the DD75 is designed and engineered for precision and convenience. One press of a button permits *electronic* selection of 33½ or 45 rpm platter speed; after a record is played, a photo-electronic trip brings the platter to a smooth stop and lifts the tonearm *automatically* by means of a solenoid. The cue control is damped to lower the stylus gently into the groove. The user will also note that all controls are sensibly grouped for easy access, reflecting Garrard's sensitivity to *human* engineering.

The platinum silver/rosewood base of the DD75 rests on shock-resistant pads which absorb external vibration. The tinted dust cover is joined to the base by spring loaded, balanced hinges which permit intermediate positioning of the cover.

These functions and features of the DD75 are in perfect congruence with the unit's specifications.

Specification

Drive system:	Direct drive
Motor:	Brushless DC, servo controlled
Platter size:	308mm (12in) diameter
Platter weight:	1,750 grams (4lb) approximately
Wow and flutter:	±0.04% peak (weighted)
Rumble:	-70dB (DIN B)
Power consumption:	6½ watts
Power requirements:	110/125 volts AC, 60Hz
Tonearm:	Direct counterbalance type, tubular, 'S' shape
Tracking error:	16min/cm
Tonearm mass:	16 grams
Horizontal pivot friction:	15 milligrams
Vertical pivot friction:	15 milligrams
Accepted cartridge weight:	4 to 9 grams
Minimum stylus force:	¾ gram
Size of unit with cover closed:	17¼in wide by 14⅞in front to rear by 6¼in deep (see also instruction section 12)
Weight:	7.3 kilograms (16lb 2oz)

Safety regulation

WARNING: To prevent fire or shock hazard, do not expose this appliance to rain or moisture.

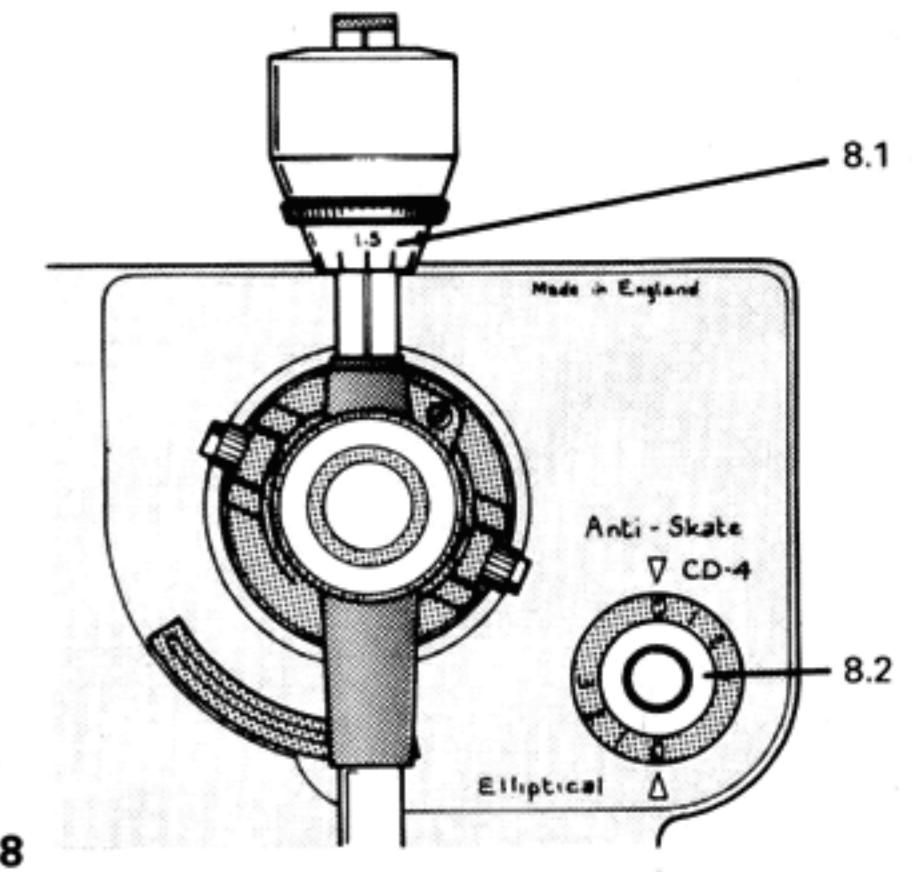

8

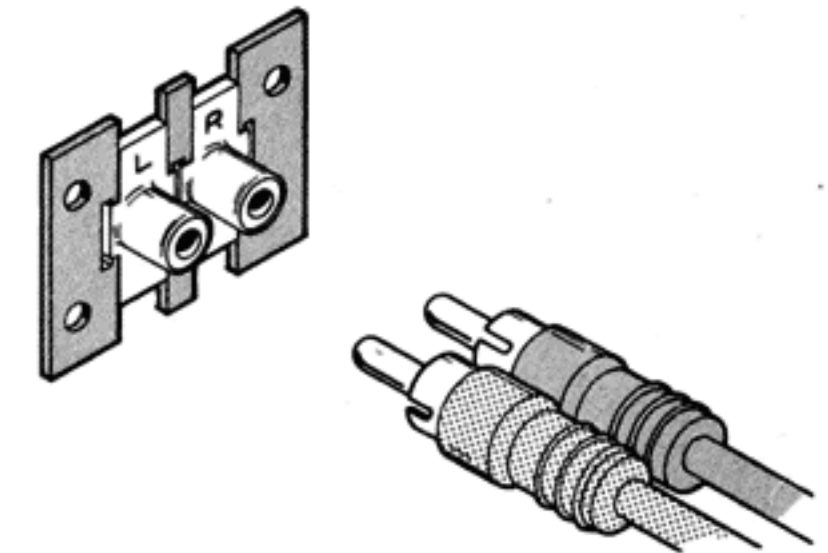

10

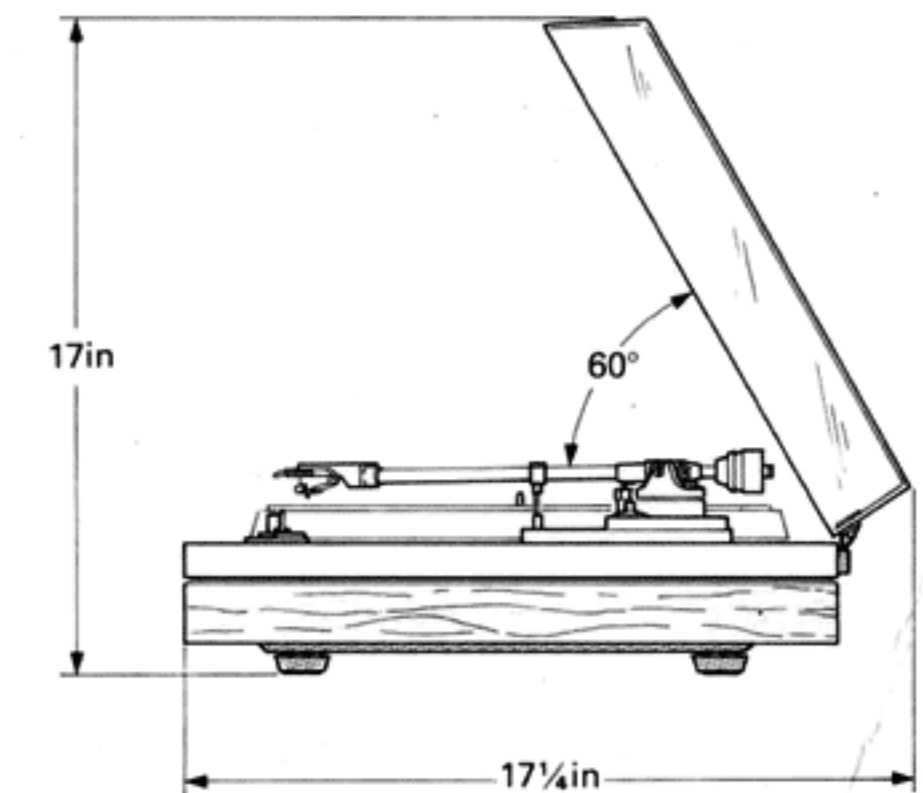

12

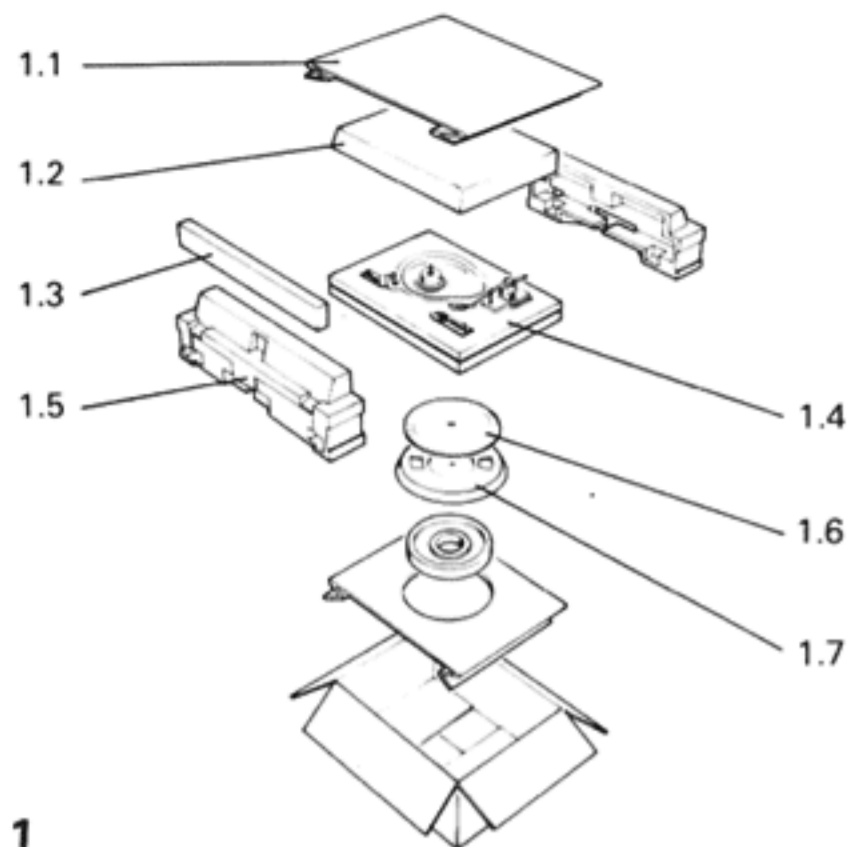

1 Unpacking sequence

- 1 With the pack open, remove the cardboard sheet (1.1).
- 2 Carefully lift clear the dust cover (1.2) and plastic bag. Try to avoid finger-marking the cover. Do not let children play with the plastic bag.
- 3 The cover packing piece (1.3) should be removed with the cover.
- 4 Carefully lift clear the module unit (1.4), gripping with hands slid between the carton and module base at each side. Do not touch the tonearm at this stage.
- 5 Withdraw cradles (1.5) and stand the module unit on its mounting pads. Remove all hardware/accessories recessed in the polyfoam cradles (1.5).

- 6 Carefully lift clear the mat (1.6) and heavy platter (1.7).
- 7 The remaining packing items illustrated need not be removed.
- 8 Carefully remove the tie holding the tonearm to its side rest. Leave the tonearm clipped to its rest.
- 9 Store the packing for re-use, in case of relocation.

2 Hardware list

Besides your module with connecting leads and dust cover, the package contains: platter (2.1), mat (2.2), cartridge holder (2.3), cartridge setting gauge (2.4), large hole record adaptor (2.5), counterbalance weight (2.6).

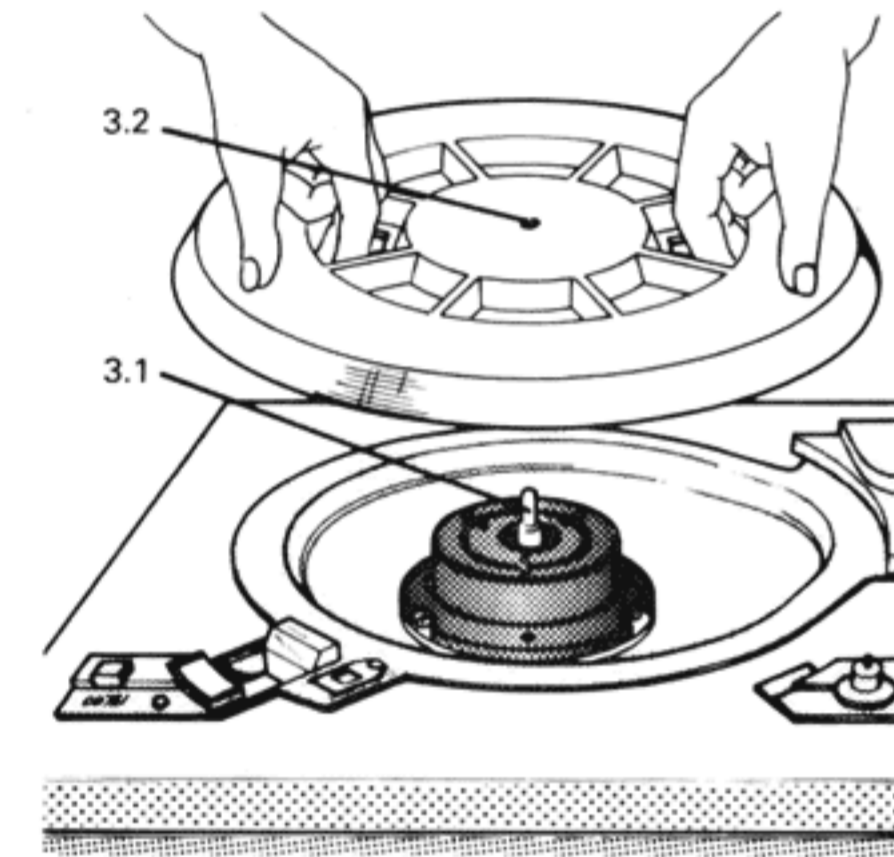
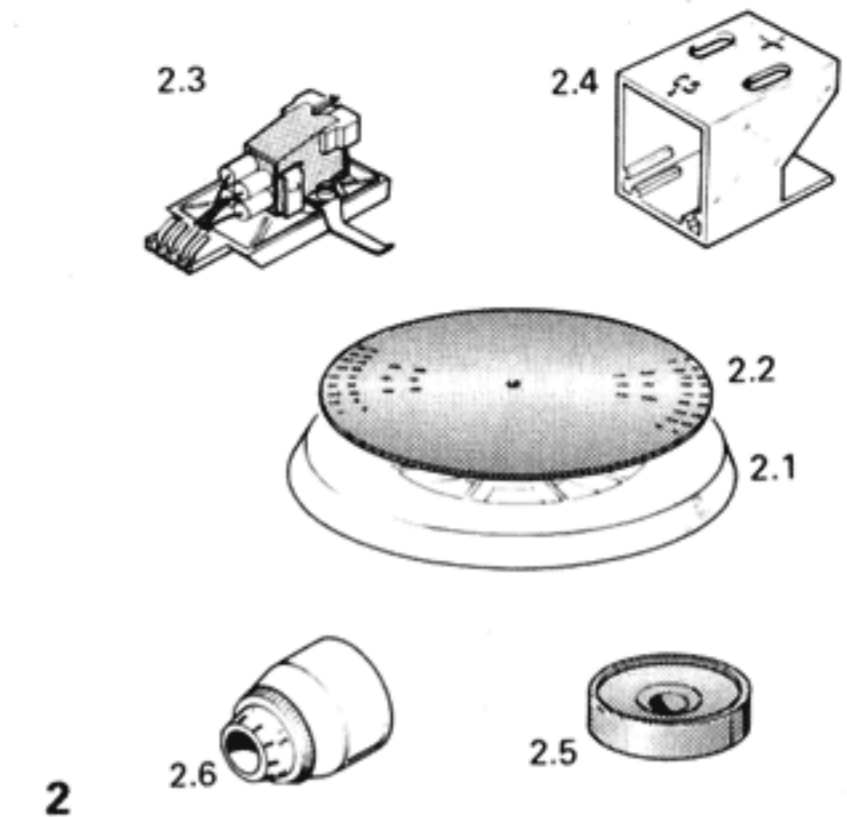

3 Platter and mat

Wipe the motor spindle (3.1) and platter center hole (3.2) with a clean dustcloth. Grip the platter by means of its two clearance holes then carefully fit the platter to the tapered motor spindle. Now place the mat concentrically on the platter. Take care not to damage any part of the module deck with the edge of the platter when fitting. If you ever need to remove the platter, it should lift straight from the tapered motor spindle. If necessary, however, have an assistant *gently* tap the

top of the spindle to loosen the platter as you lift.

4 Module unit and cover

Fit the dust cover (4.1) to the base (4.3) first aligning the two cover hinges (4.2) with their slot locations at the rear of the module. *The hinges are spring loaded, therefore the cover must only be fitted or removed when set at its raised open position.*

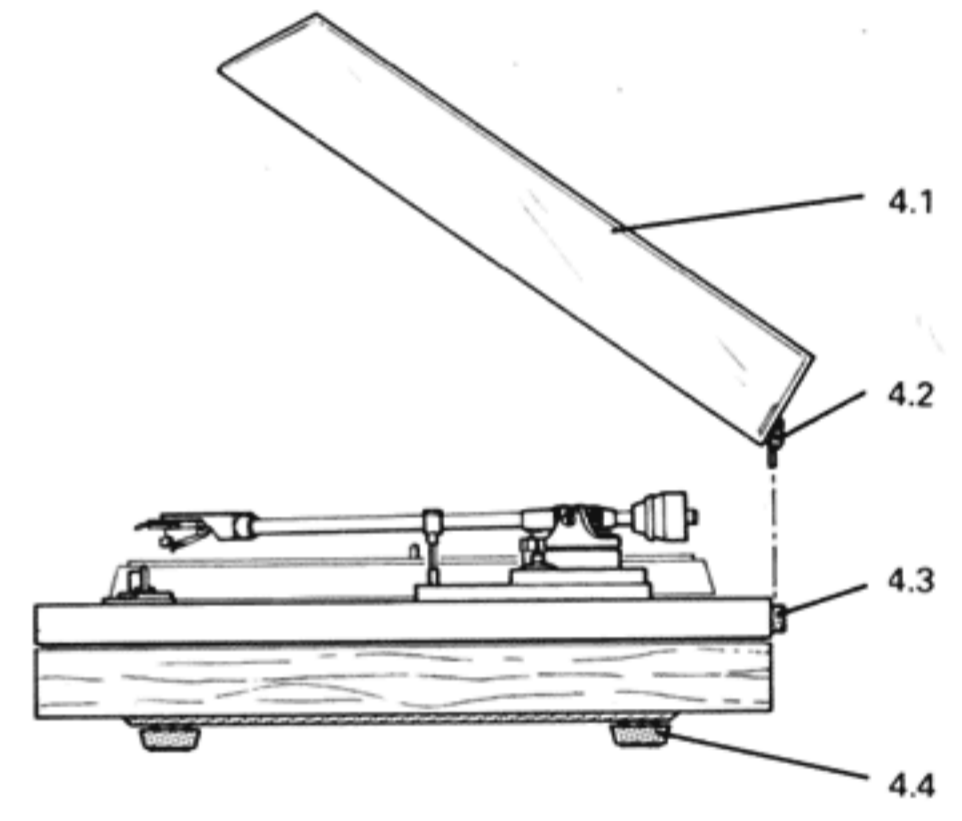

5 Fitting cartridge holder

(when supplied with factory-installed cartridge. Details on inspection label.)

Unclip the tonearm and support it over the platter. Simply assemble the holder to the tonearm head as shown in diagram 5, then resecure the tonearm.

6 Fitting cartridge to holder

(when supplied less cartridge)

- 1 Withdraw cartridge holder (6.5) from head and assemble finger lift (6.4) and cartridge (6.2) using nuts (6.6) and non-protruding screws (6.1).
- 2 Include weight (6.3) next to finger lift if a lightweight cartridge (4 grams) is to be fitted:

- 3 Before fully tightening the screws, fit the setting gauge as shown and carefully move the cartridge (any stylus guard removed) to set the stylus below the cross-lines on the gauge. (If you have misplaced the setting gauge align the stylus over the 'T' junction lines marked on the holder.)
- 4 Tighten screws (6.1) and recheck cartridge squareness and stylus position.
- 5 Attach the pickup leads to the cartridge following the manufacturer's instructions and the code:
Red – right signal
Green – right ground
White – left signal
Black or blue – left ground
Do not solder leads directly to the cartridge.
- 6 Replace the cartridge holder securely in the tonearm head.

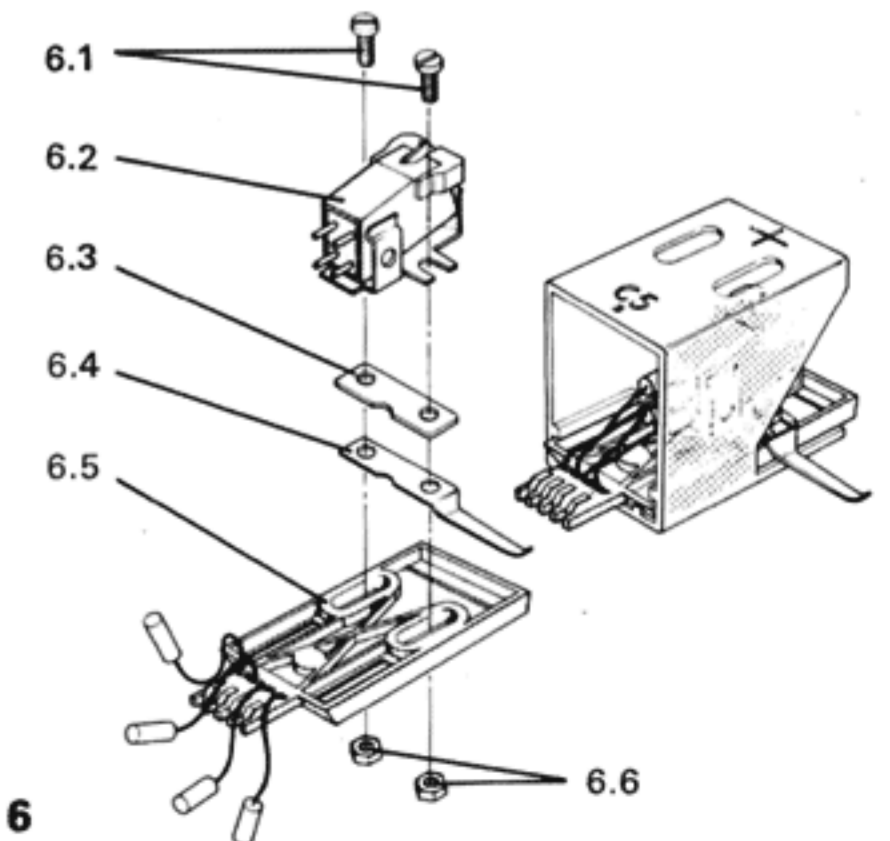
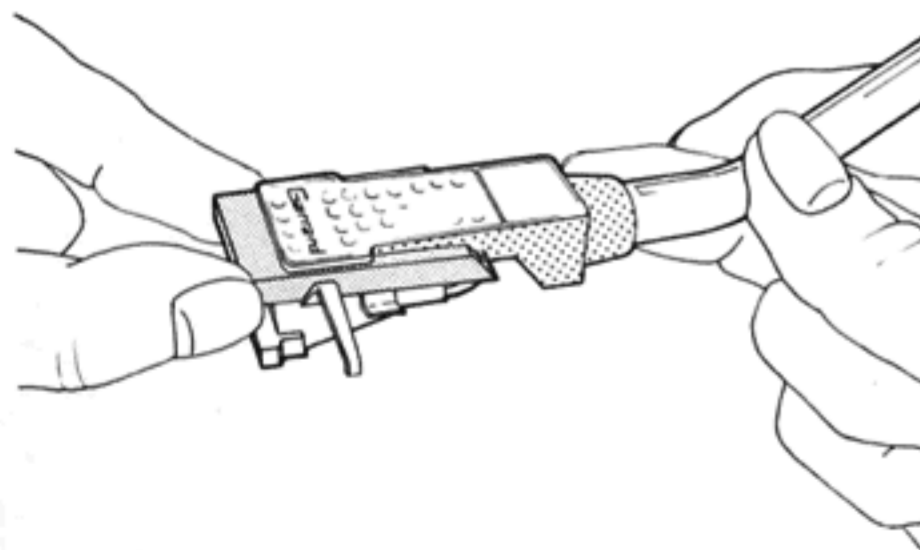

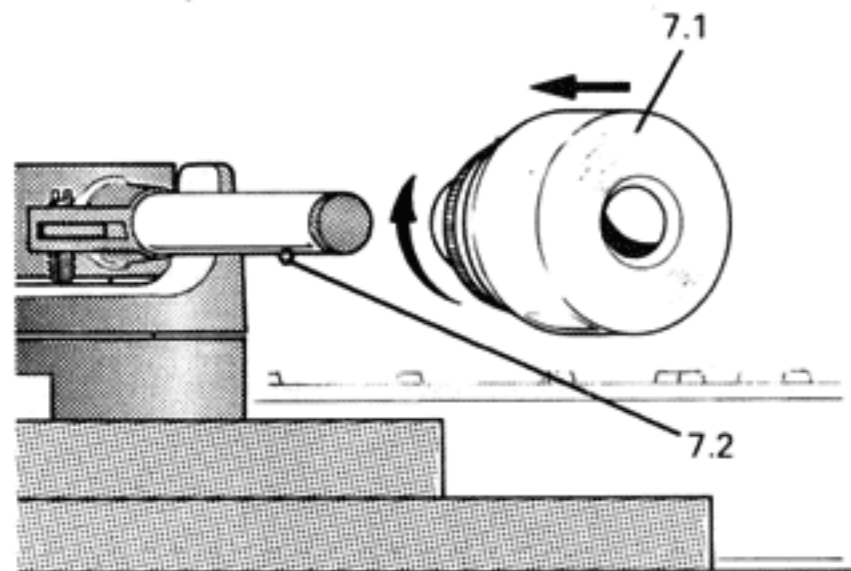

7 Tonearm balance

- 1 Fit the counterbalance weight (7.1) so that its internal spiral groove forms a winding key with the spring-loaded pip (7.2) under the arm. See diagram 7.
- 2 Remove any stylus guard fitted and turn the anti-skate control (8.2) to 0 (to stop the arm from drifting out unduly whilst balancing).
- 3 Move the cue control at the front of the unit (temporarily) to ∇ then unclip the tonearm and support it by hand over the platter.
- 4 Wind the weight to the position which balances the tonearm with the cartridge stylus tip about 3mm ($\frac{1}{8}$ in) above the mat.
- 5 Clip the tonearm to its rest and set the cue control ∇ .

7

8 Stylus force and anti-skate

- 1 Hold the body of the weight stationary and rotate only its calibrated collar (8.1), aligning the zero with the marker line on the arm.
- 2 Now wind the whole weight towards the front (do not push or pull) until the marker line is set to the figure on the collar representing stylus force required.
- 3 Turn the anti-skate control (8.2) to correspond with the stylus force figure. Read off the scale marked 'Elliptical' for an elliptical stylus or the scale marked 'CD-4' if a conical or specially profiled stylus for CD-4 records, is fitted.

Check these installation adjustments if a different cartridge and holder is ever used.

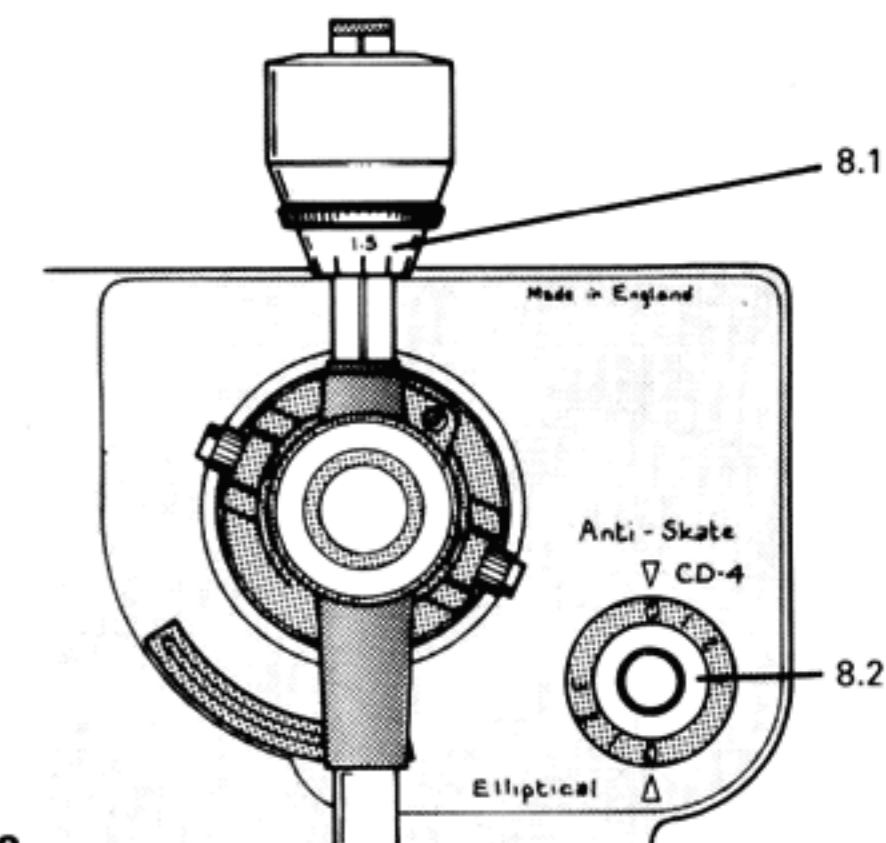

8

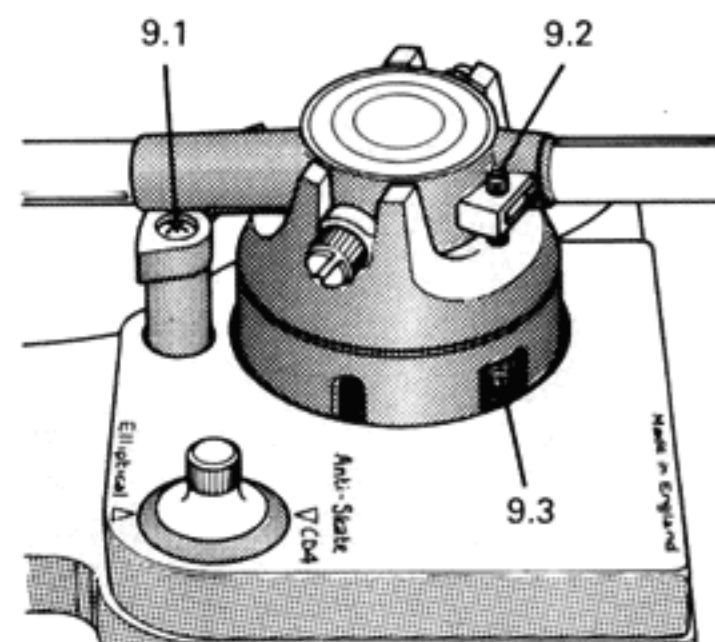

9 Tonearm adjustments

These adjustments are factory set; they should require no attention. However, should adjustment be required, proceed as follows making fractional turns of the appropriate adjustment screw:

Cueing height. Turn screw (9.1) clockwise to reduce the cue height between the cartridge stylus and the mat. A normal setting is 6mm ($\frac{1}{4}$ in).

Tonearm height restrictor. Turn screw (9.2) clockwise to reduce height. The tonearm should lift manually 1.5mm ($\frac{1}{16}$ in) more than the cueing setting. Only increase this figure if use of the tonearm side rest is restricted.

Auto lift position. Clip the tonearm to its rest to line up the adjustment screw (9.3) with its access slot. Turn the screw clockwise if the arm lifts before the lead-out groove of standard records.

10 Phono connections

Connect the phono lead(s) from the rear of the unit to your amplifier or receiver. Connect the black phono plug to the right and the grey phono plug to the left signal phono socket (diagram 10). These input sockets may be marked 'Phono' or 'P.U.'. Plug adaptors are available from your dealer if required. Refer to the amplifier manufacturer's instructions for the selection of input level to suit your cartridge.

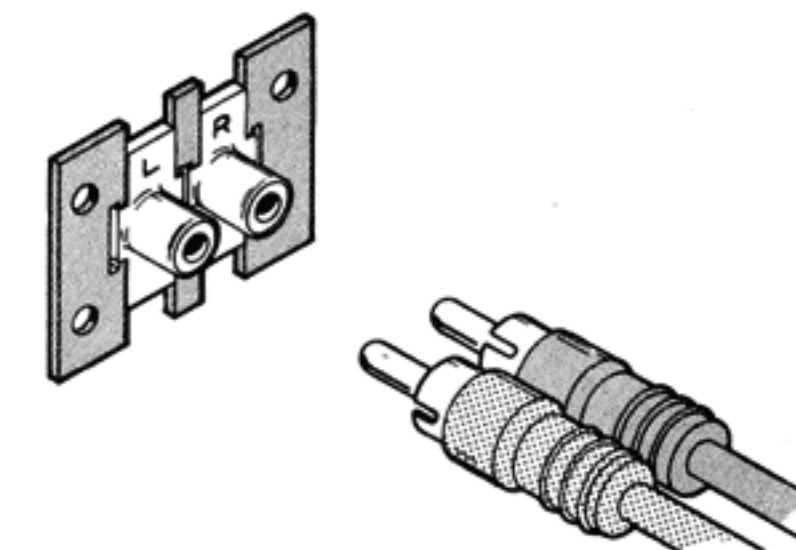

10

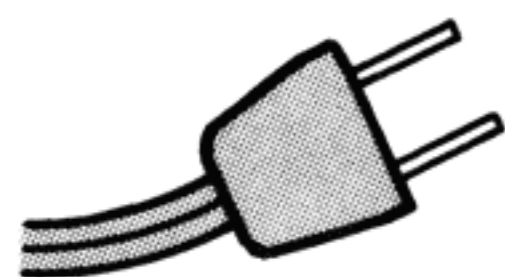

11 110/125V AC line cord connections

Connect the standard two flat-pin plug (diagram 11) from the rear of your unit to the power outlet on your amplifier/receiver or wall socket. Connect the line cord green ground lead to a reliable grounding point on the amplifier/receiver chassis or other suitable ground point.



11

12 Unit location

Check that your unit is placed with its anti-vibration feet (4.4) in a level, stable position. Diagram 12 shows shelf depth, also height with the cover open at a typical angle. See 'Specification' for actual sizes, noting that with the cover closed, shelf space of 215mm ($8\frac{1}{2}$ in) is required for its removal. Make sure that all connecting leads are arranged tidily and that complementary audio equipment is installed safely and correctly. You are now ready to use your Garrard Model DD75 Direct Drive Turntable.

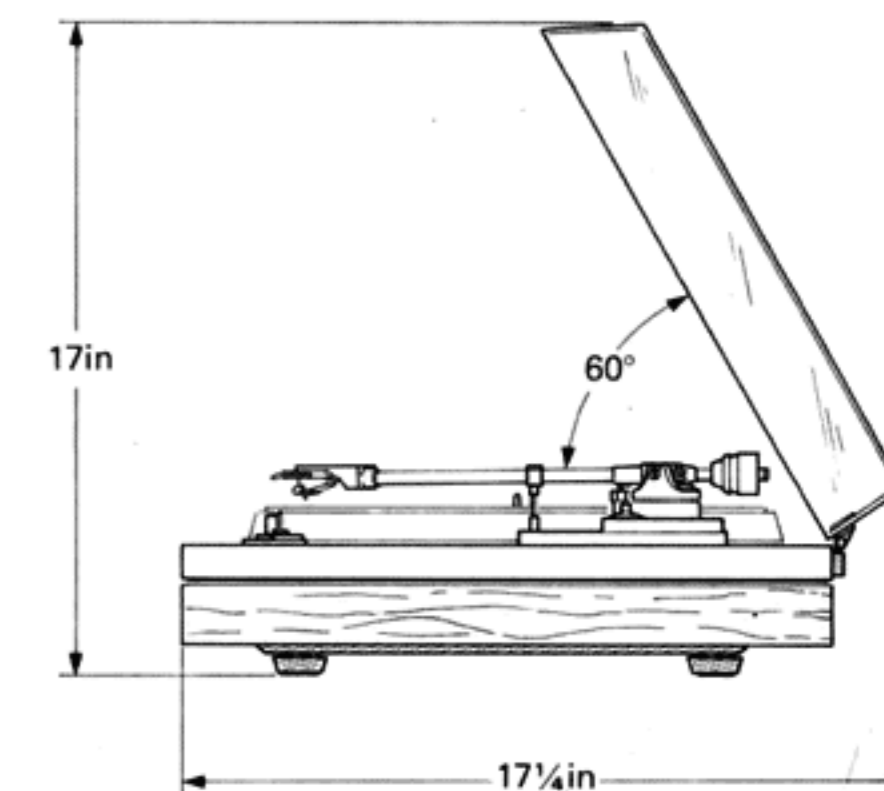

12

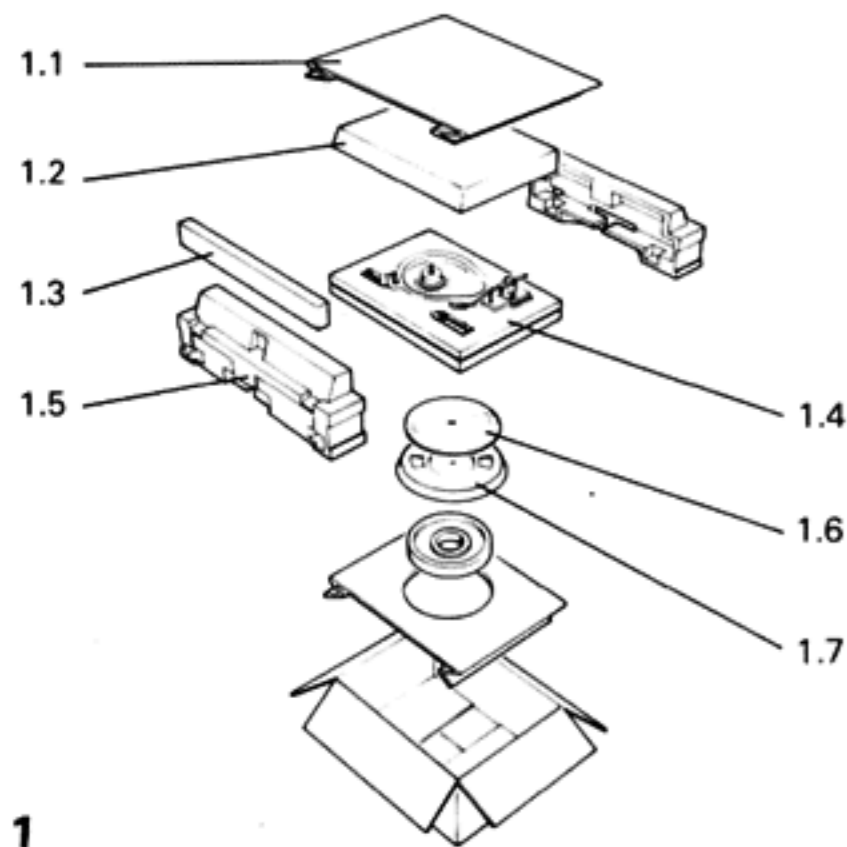

1

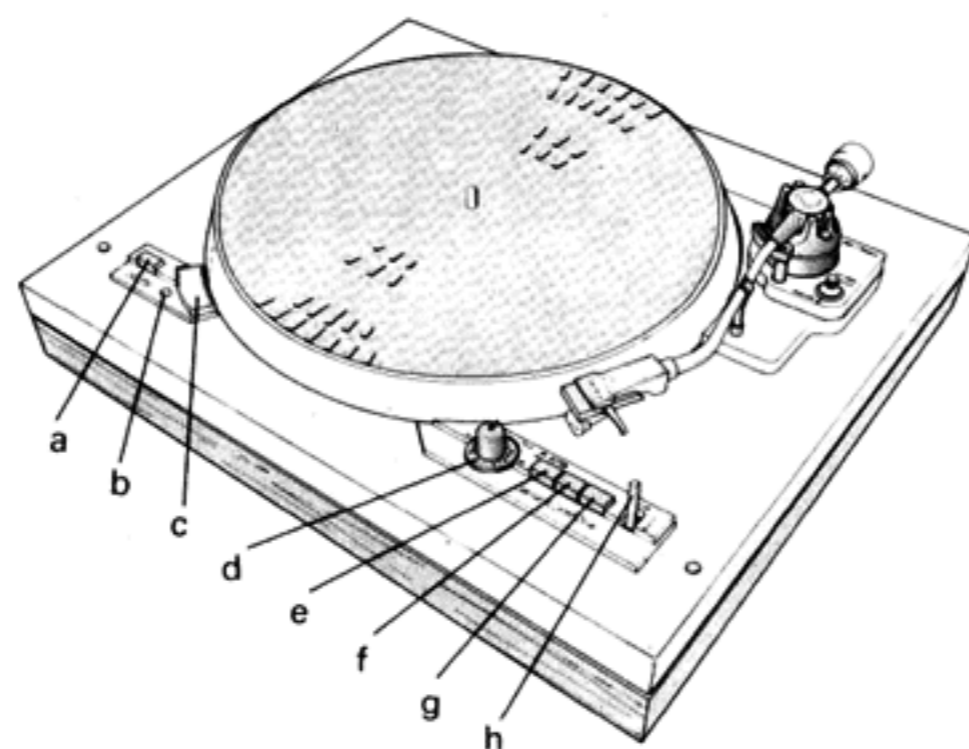



To obtain best results, store and clean records as recommended by the record manufacturers.



Keep the stylus free from accumulated dust. A recommended method is to withdraw the cartridge holder and brush dust away from the stylus with an artist's camel hair brush, working from the back of the stylus to the front to avoid bending it. Also remove and brush the platter mat if it has collected dust.

Examine the stylus under a microscope periodically for wear. Your dealer can offer this service. Replace a badly worn or chipped stylus.

Operating instructions

- 1 Remove or raise the dust cover.
- 2 Remove the cartridge stylus guard, if fitted.
- 3 Press the 'Power' button (a). The pilot lamp (b) and stroboscope viewer (c) will light.
- 4 Place a record on the platter (for a large center hole record, first fit the large hole record adaptor).
- 5 Check or select platter speed. In its up position the speed selector button (e) is set for 33½ rev/min, in its down position it is set for 45 rev/min.
- 6 Press the 'Start' button (g). The platter will revolve.
- 7 Unclip the tonearm and set it with its cartridge stylus over the record where required.
- 8 Move the cue and pause lever (h) to its  position. The tonearm will lower gently on to the record and commence play.
- 9 If desired, check platter speed or set the pitch control (d). See note below.
- 10 After playing the record the tonearm will lift automatically, the cue and pause lever will move to its  position and the platter will stop. Return the tonearm to its rest.



Cue and pause

Move the cue and pause lever (h) to its  position. The tonearm will lift from the record and may be set, using the tonearm finger lift, over another record band, if desired. To resume play, move the cue and pause lever to its  position.

Stroboscope and pitch control

The stroboscope display (c) appears stationary at the nominal platter speed. If the pitch control (d) is moved '+' the bars of the display will appear to drift clockwise, speeding up as platter speed increases. If the pitch control is turned '-' the bars of the display will appear to drift counterclockwise, speeding up in this direction as platter speed decreases. The pitch control allows adjustment to suit accompanying musical instruments or correction of out of pitch recordings.

To stop during play

Press the 'Stop' button (f). The tonearm will lift, the cue and pause lever will move to its  position and the platter will stop. Either return the tonearm to its rest or resume play by pressing the 'Start' button and moving the cue and pause lever to its  position. Switch off Model DD75 after use by pressing the 'Power' button (a). Remove the record and replace or close the dust cover.

Note: If you switch off the 'Power' button during play, the tonearm will remain on the record.

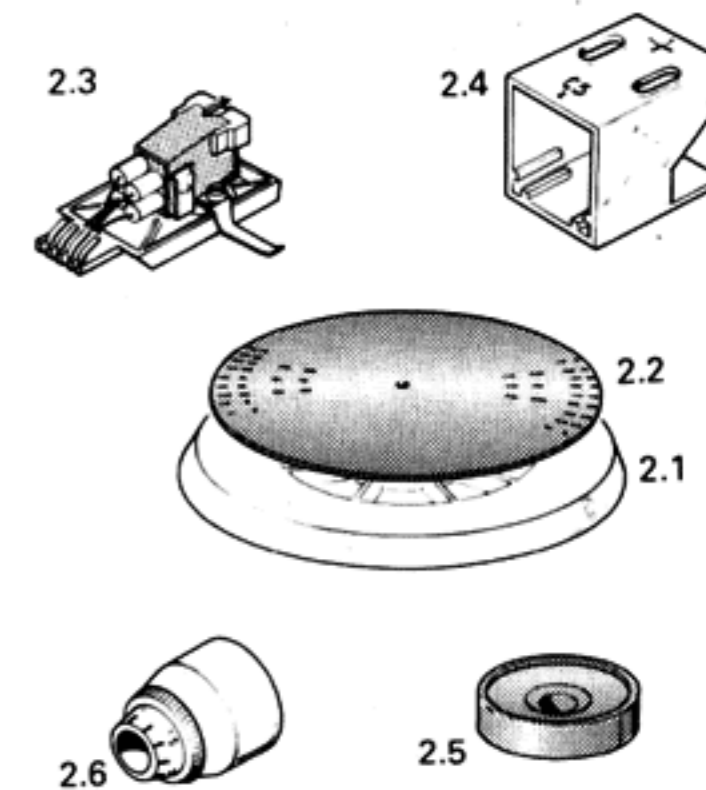

2

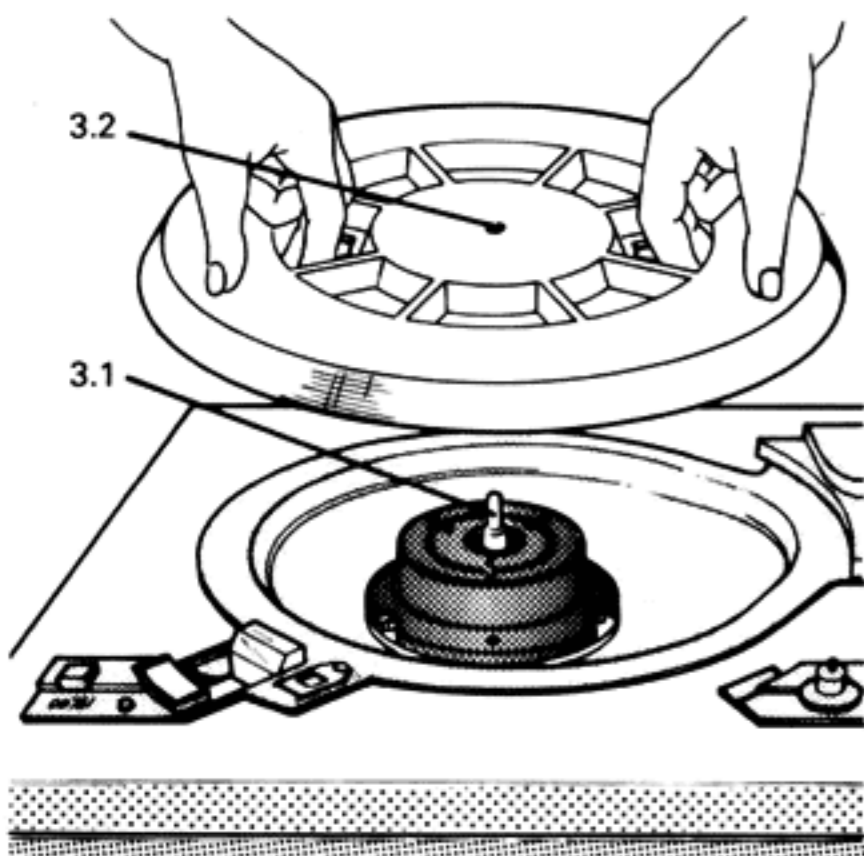

3

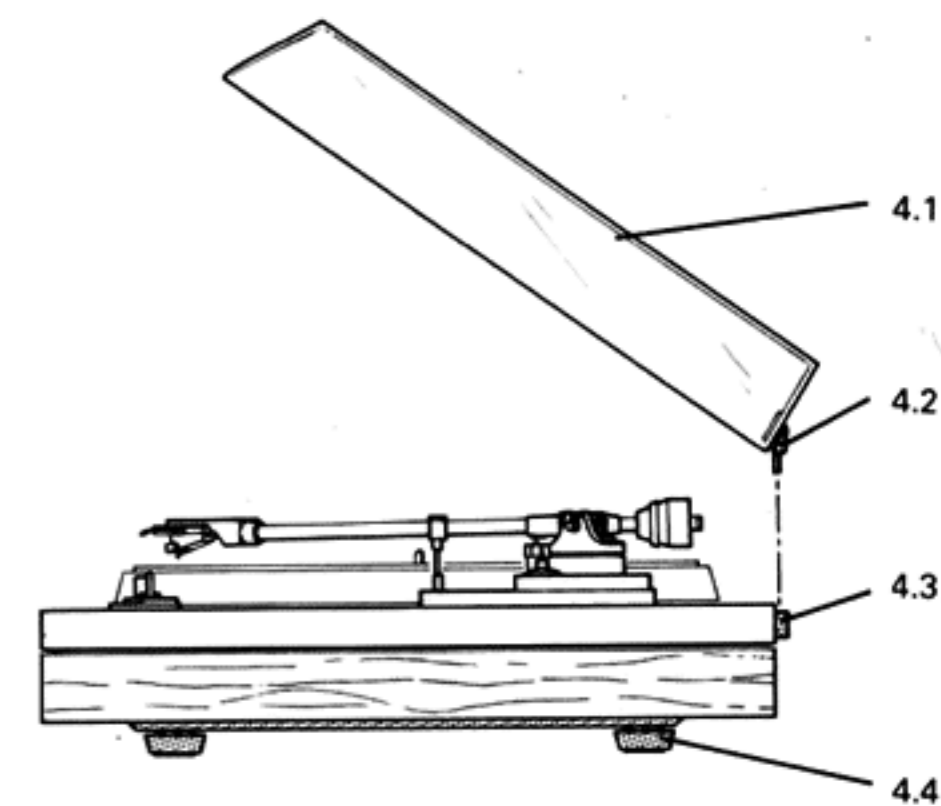

4

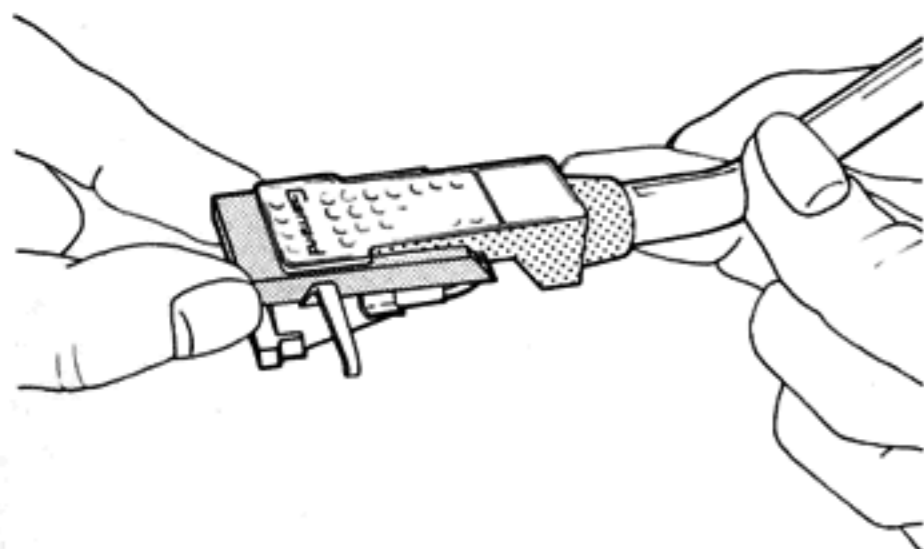

5

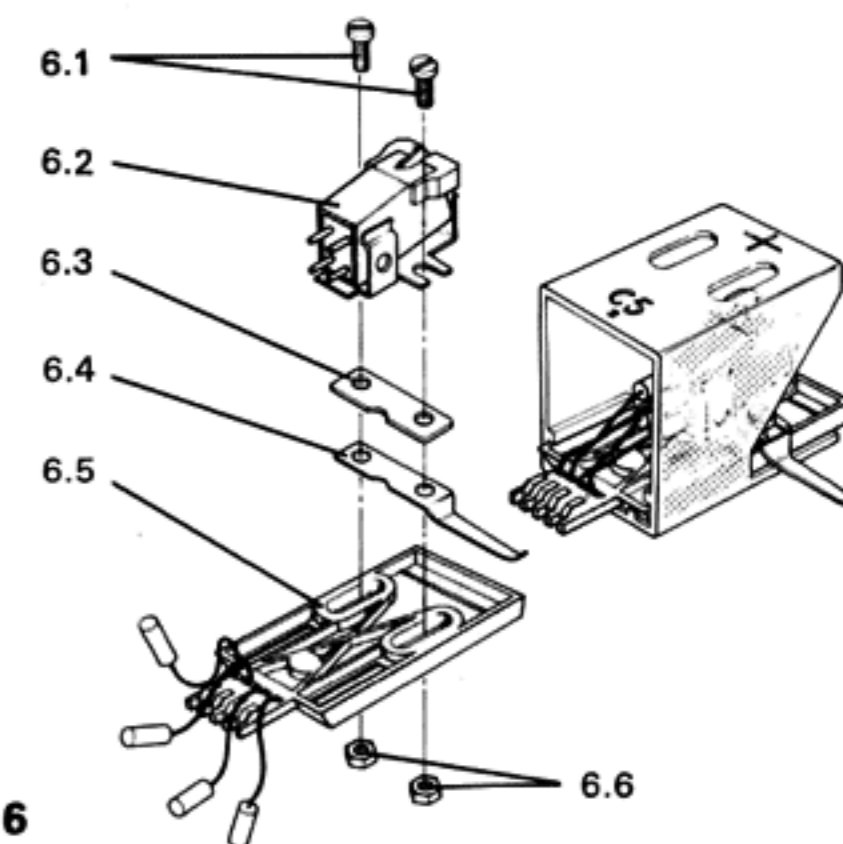

6